

Electric Rotary Valves



6 Port Switching Electric Rotary
Valve w/ Stepper motor and
controller PCB



INDEX

Page 3 **Electric Rotary Valve Selection Guide**

Page 4 **RV-E Series Electric Rotary Valves**
PTFE/PCTFE rotary valve head assembly (supplied without motor or PCB)



Page 5 **RV-SN Series Electric Rotary Valves - valve with motor**
PTFE/PCTFE rotary valve supplied with Trinamic stepper motor



Page 6 **RV-SC Series Electric Rotary Valves - valve with motor and controller PCB**
PTFE/PCTFE rotary valve supplied with Trinamic stepper motor and intelligent motor controller



ELECTRIC ROTARY VALVES GENERAL INFORMATION

What is an Electric Rotary Valve?

The Bio-Chem Fluidics Electric Rotary Valve is a stepper motor operated device used in sample collection, loop injection or flow path selection applications. It is designed to provide an inert flow path for aggressive and/or reactive fluids. The inert path is achieved by aligning holes in a PCTFE rotor with holes in the PTFE valve body (stator).

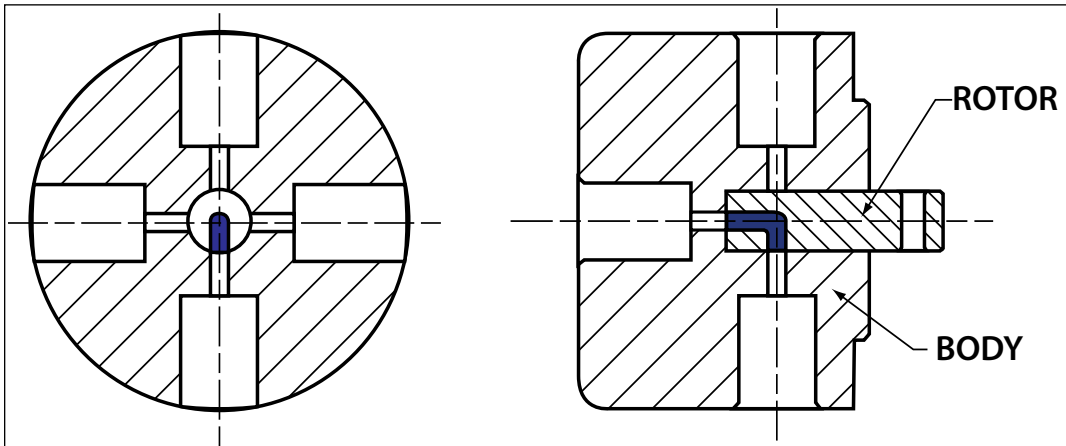

The rotor is pressed into the valve body creating a tight interference fit seal. The rotor is turned by a close-coupled two-phase hybrid stepper motor. An optoelectronic position sensor inside the valve provides the position of the rotor to a controller PCB. The PCB makes fine adjustments as necessary to provide an uninterrupted path. The end-user can program the valve controller to perform desired position sequences - the rotor can move clockwise or counter-clockwise to the desired port position. *(The Bio-Chem Fluidics Electric Rotary Valve can also be supplied without the motor and controller - refer to page 4 for more details).*

Features of a Bio-Chem Fluidics Electric Rotary Valve

- **Inert fluid path** - the fluid in the valve is in contact with only two components; the PTFE valve body and the PCTFE rotor. This ensures a completely non-metallic, corrosion-resistant path and means that the non-contact parts can be sourced economically from industry standard components.
- **Multiple flow configurations** - the Bio-Chem Fluidics Electric

Rotary Valve is available in five different flow configurations (see page 3 for more details) which means that the most appropriate design for your application can be selected from standard configurations.

- **Unobstructed flow path** - careful and precise machining results in an unobstructed flow path through the valve ensuring minimized dead volumes and providing a lower pressure drop than conventional solenoid mixing valves.
- **Industry standard stepper motor** - Bio-Chem Fluidics

Electric Rotary Valves utilize Trinamic® QMOT stepper motors and PANdrive motor controllers.

- **OEM focused** - the RV series Electric Rotary Valve is designed specifically with OEM customers in mind. The flow configurations match the most commonly found applications and the 1/4"-28 UNF fluid port connections allow easy integration into sophisticated systems.

Polymers referenced in this brochure:

PCTFE = polychlorotrifluoroethylene
PTFE = polytetrafluoroethylene

Electric Rotary Valve Selection Guide

The Bio-Chem Fluidics RV series of Electric Rotary Valves is available in three versions; the RV-E series comprises the valve head assembly only with no motor or controller, the RV-SN series couples the valve head assembly to a two-phase hybrid stepper motor to drive the valve's rotor and the RV-SC series adds an intelligent controller / driver PC board with the stepper motor.

The RV-SC can be used in two distinct modes; Stand Alone-mode where external programs can be downloaded directly in the controller's EEPROM memory, and Direct-mode where the controller acts as a "slave" board in conjunction with a "master" external control system. (More details on operating modes on page 6).

Flow Switching Configurations and Part Numbers

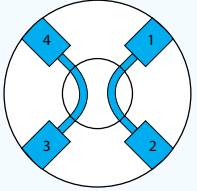
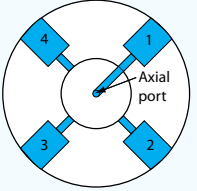
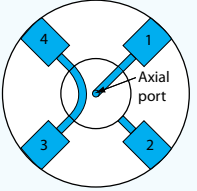
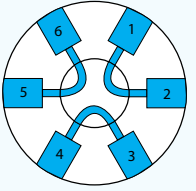
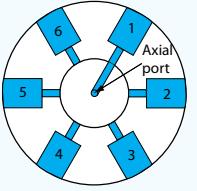
		Flow configurations				
						
Valve version		4 port switching	4-way selection / distribution	4-way combination	6 port switching	6-way selection / distribution
Part nos.	Valve head assy. (page 4)	RV-EN0-J4C-PTNB	RV-EN0-S4C-PTNB	RV-EN0-N4C-PTNB	RV-EN0-J6B-PTNB	RV-EN0-S6B-PTNB
	Valve w/motor (page 5)	RV-SN2-J4C-PTNB	RV-SN2-S4C-PTNB	RV-SN2-N4C-PTNB	RV-SN2-J6B-PTNB	RV-SN2-S6B-PTNB
	Valve w/motor and controller (page 6)	RV-SC2-J4C-PTNB	RV-SC2-S4C-PTNB	RV-SC2-N4C-PTNB	RV-SC2-J6B-PTNB	RV-SC2-S6B-PTNB

Applications

Bio-Chem Fluidics Electric Rotary Valves are typically used in one of two main applications; port selection applications where one stream is diverted to one of either 4 or 6 different places, and loop injection applications where the valve can be used to load and inject fluids into a sample loop in two discrete steps.

Port selection

Bio-Chem Fluidics 4-way and 6-way selection / distribution valves allow for accurate and repeatable flow re-direction. One input can be diverted to any one of 6* outlets, or, 6* separate inputs can be diverted to one common outlet. (*Note: 4-way valves have 4 possible outlets / inputs).

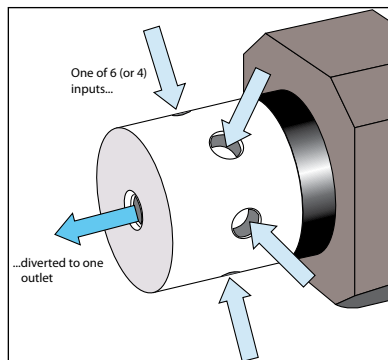
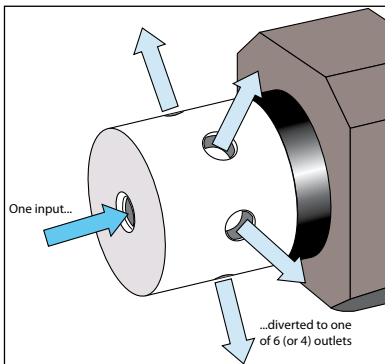

Loop injection

Bio-Chem Fluidics 4 port and 6 port switching valves are commonly used as sample injection devices for chromatography systems. This application is comprised of two distinct operations: Load and Inject.

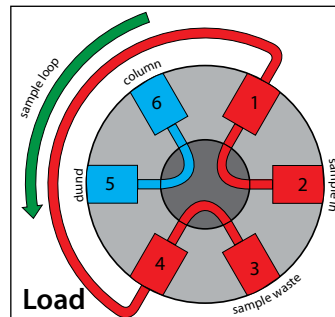

Step 1 - the sample can be loaded into the sample loop while the mobile phase is pumped directly through to the column.

Step 2 - when the valve switches to the inject position, the pump connects to the sample loop and the sample is carried onto and through the column. The "sample in" and "waste" ports are joined but are isolated from the loop.

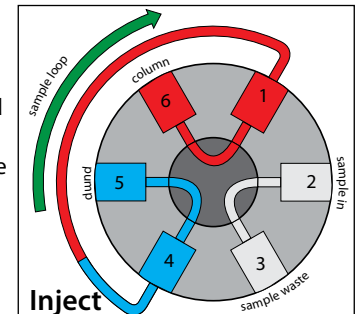

RV-E SERIES ELECTRIC ROTARY VALVES - (Valve head assembly - no motor)

Economic PTFE/PCTFE Rotary Valve option for OEM clients with knowledge and experience with mounting their own stepper motors.

- Inert flow path - only the PTFE valve body and PCTFE rotor are in contact with the fluid
- 1/4"-28 UNF, flat bottomed fluid connection ports with stainless steel threaded inserts for extra strength and durability
- A two-channel optoelectronic position sensor and optical encoder disc are incorporated into the valve. This position sensor allows for referencing the "home" position after the unit is powered up and for signalling that the valve has reached a valid "port" position
- Incorporates an internal coupling that mates the valve's rotor to the driving source
- Mounting dimensions fit NEMA 17 stepper motors

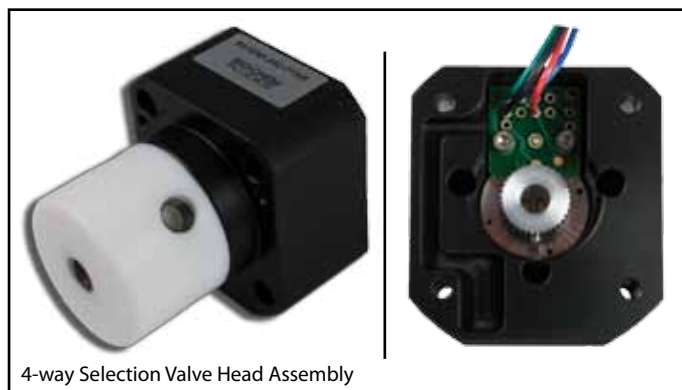

Valve specifications

	4 port valve			6 port valve	
	4 port switching	4-way selection / distribution	4-way combination	6 port switching	6-way selection / distribution
Part number	RV-EN0-J4C-PTNB	RV-EN0-S4C-PTNB	RV-EN0-N4C-PTNB	RV-EN0-J6B-PTNB	RV-EN0-S6B-PTNB
Operating pressure (max)	200 psi (13.6 bar)			150 psi (10.3 bar)	
Flow path/orifice diameter	0.052" (1.32mm)				
Internal volume*	18.5 µl	20.4 µl	18.9 µl	15.3 µl	18.2 µl

* one complete path

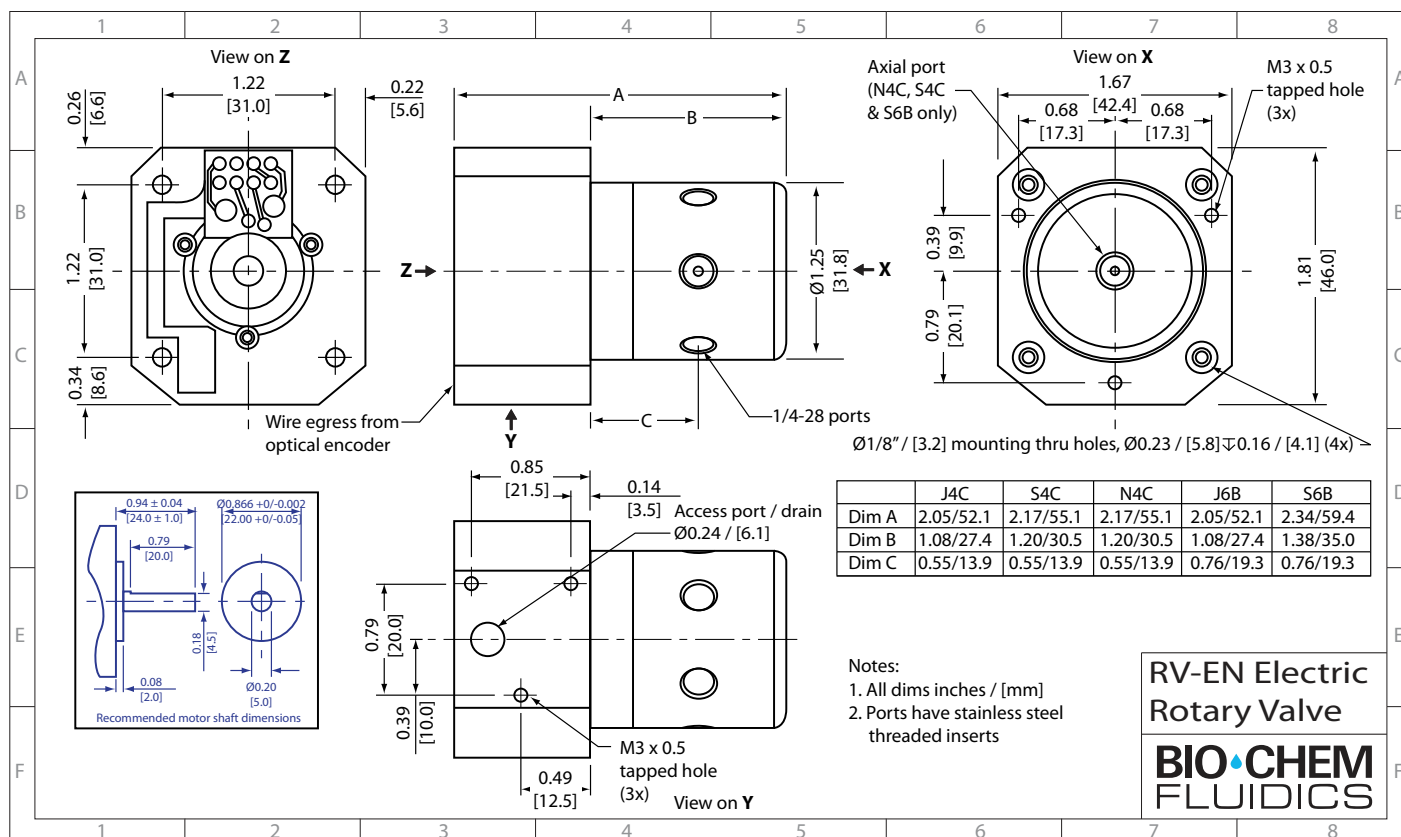

RV-SN SERIES ELECTRIC ROTARY VALVES - (Valve with motor)

Electric Rotary Valve close-coupled to industry standard two-phase, hybrid stepper motor

- All valve features as shown on page 4
- Trinamic® QMOT Stepper motor
- Motor features:
 - 1.8° step angle
 - Optimized for microstep operation
 - 4 wire connection
 - Neodymium magnets for maximum torque
- Valve functionality details:
 - Life of assembly - up to 1,000,000 port-to-port cycles
 - Port-to-port move time - 250 ms
 - Maximum duty cycle (recommended) - 12.5%



Motor specifications

	4 port valve			6 port valve	
	4 port switching	4-way selection / distribution	4-way combination	6 port switching	6-way selection / distribution
Part number	RV-SN2-J4C-PTNB	RV-SN2-S4C-PTNB	RV-SN2-N4C-PTNB	RV-SN2-J6B-PTNB	RV-SN2-S6B-PTNB
Motor part number	QSH4218-41-10-035			QSH4218-51-10-049	
Rated voltage	4.5V			5.0V	
Rated phase current	1.0A			1.0A	
Phase resistance	4.5 Ω			5.0v Ω	
Phase induction	7.5 mH			8.0 mH	
Holding torque	35 cN·m / 50 ozin			49 cN·m / 69 ozin	

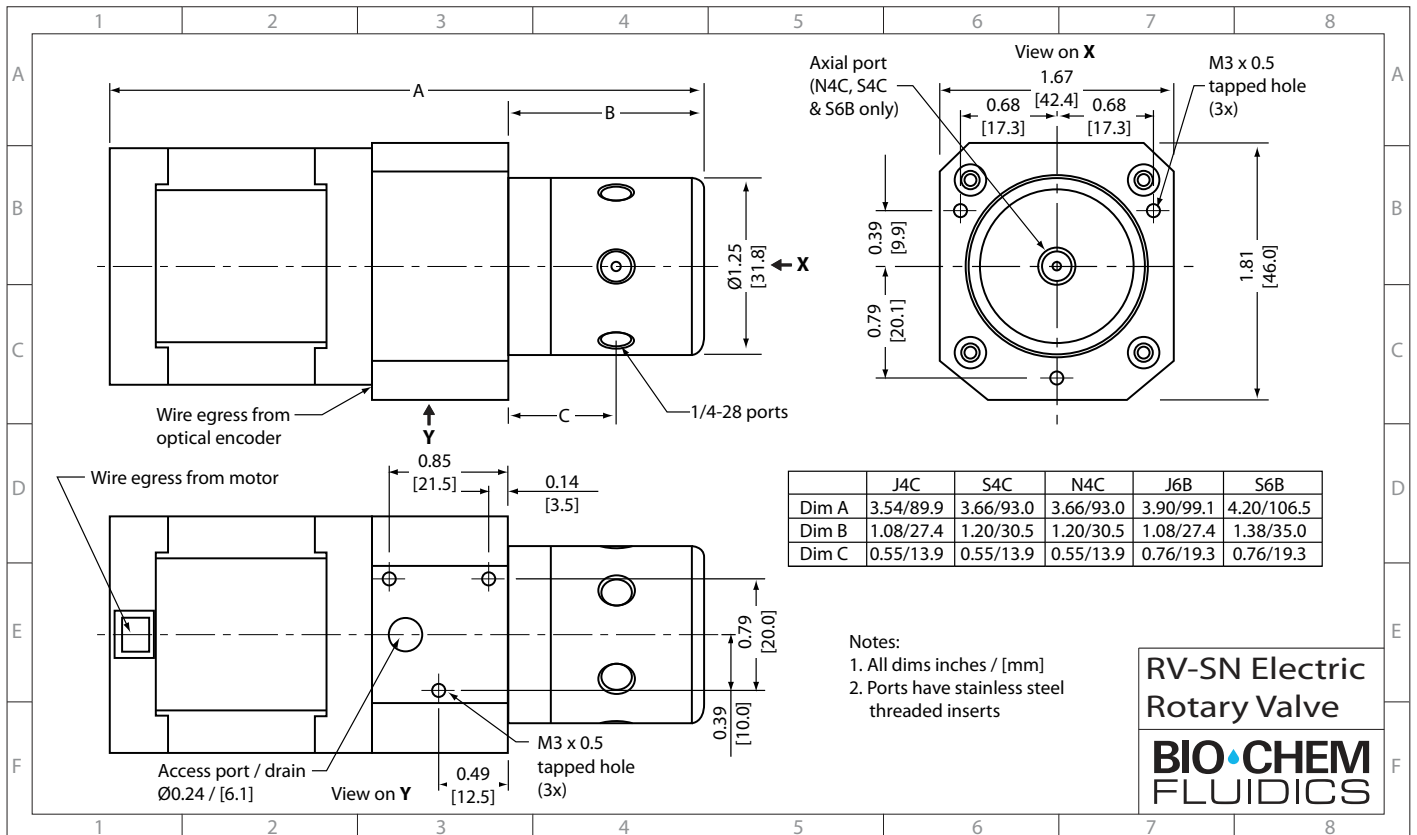

RV-SC SERIES ELECTRIC ROTARY VALVES - (Valve with motor and controller PCB)

Electric Rotary Valve close-coupled to industry standard two-phase, hybrid stepper motor with intelligent motor controller and driver

- Valve and motor features as pages 4 & 5
- Trinamic® PANdrive Motor controller and driver
- Controller features:
 - PC-based software development environment (Trinamic® IDE)
 - High level commands
 - RS-232 communications protocol
 - On board EEPROM for stand-alone operation

Modes of operation:

Stand-alone – In Stand-alone mode the controller is used to provide operating signals to the valve from programs downloaded into the on-board EEPROM memory. The end-user has the option to start the programs automatically with power-on (Auto-start ON) or to have them start upon receiving an external trigger (Auto-start OFF).

Direct mode – In Direct mode commands from a master controller are issued one-at-a-time to the valve controller which is operating as a slave unit only. Although the valve controller is still responsible for sending signals to the valve, it retains no instructions on-board.

Note: Part numbers are the same for both modes of operation.

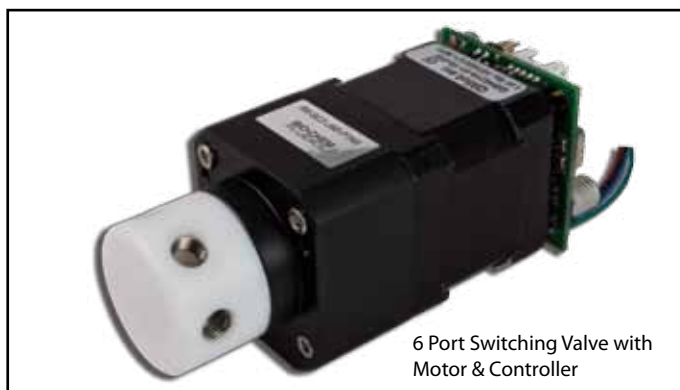

6 Port Switching Valve with Motor & Controller

	4 port valve			6 port valve	
	4 port switching	4-way selection / distribution	4-way combination	6 port switching	6-way selection / distribution
Part number	RV-SC2-J4C-PTNB	RV-SC2-S4C-PTNB	RV-SC2-N4C-PTNB	RV-SC2-J6B-PTNB	RV-SC2-S6B-PTNB
Motor part number	QSH4218-41-10-035			QSH4218-51-10-049	
Controller / drive module part no.	PD2-110-42-232			PD3-110-42-232	

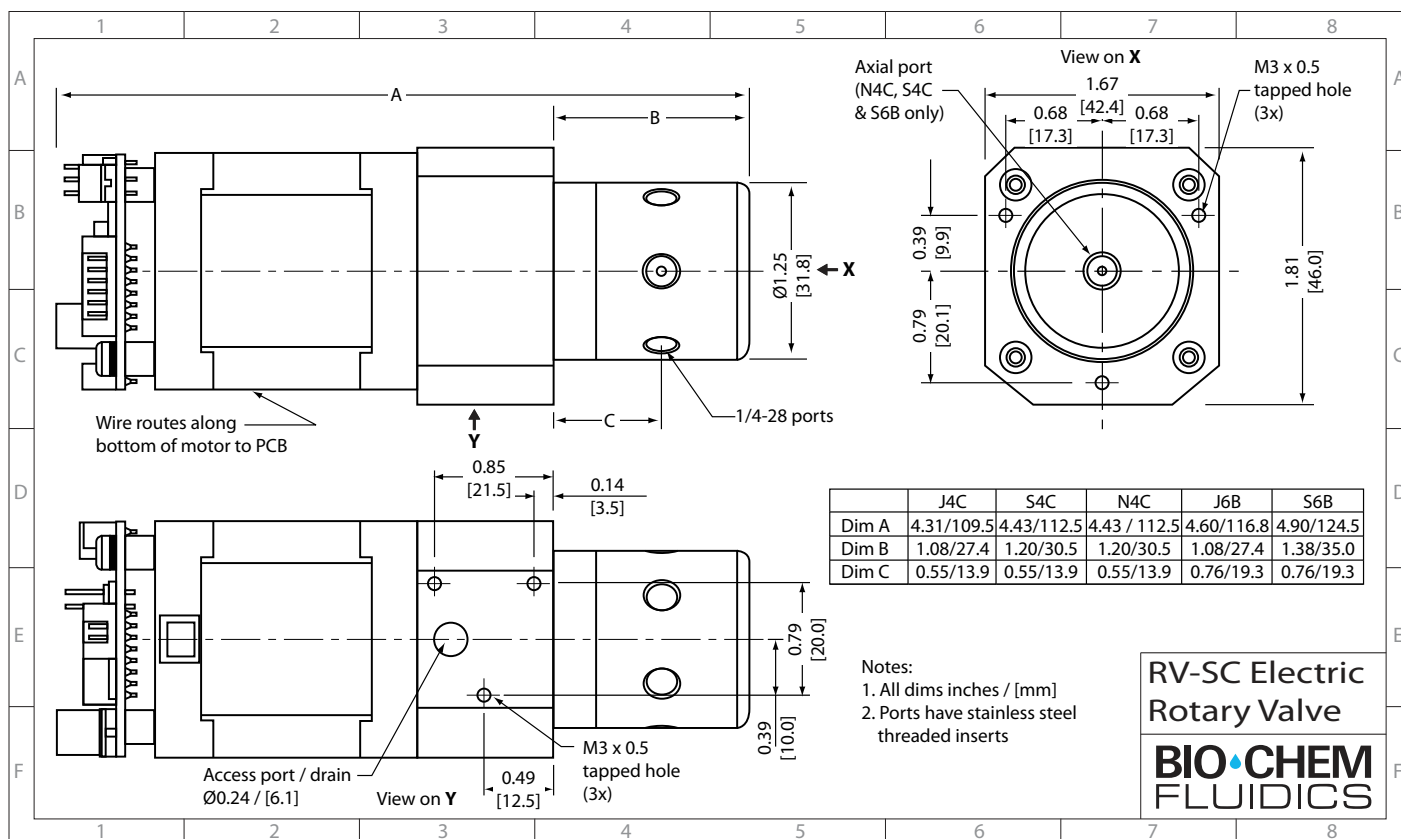

THE BIO-CHEM FLUIDICS BRAND FAMILY

Bio-Chem Fluidics is dedicated to providing instrument manufacturers and laboratories with the industry's best choice of inert, miniature fluid handling components.

Under the Bio-Chem Valve™ brand name we offer a complete fluid system solution for a wide range of industries including analytical chemistry, clinical diagnostics and medical device manufacturers as well as the scientific community.

BIO-CHEM VALVE

INERT SOLENOID VALVES AND PUMPS, ELECTRIC ROTARY VALVES

MICRO-PUMPS



ISOLATION VALVES



FLOW SELECTION VALVES

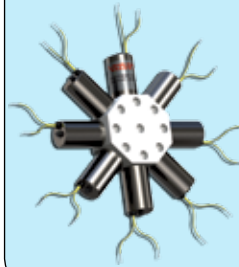

PINCH VALVES



ELECTRIC ROTARY VALVES



MANIFOLD ASSEMBLIES



ACCESSORIES



CUSTOMIZATION SERVICES



INERT FLUID HANDLING COMPONENTS AND ACCESSORIES

- 1/4"-28, 5/16"-24, and M6 fittings for pressures up to 1000 psig
- CoolCube™, "Hit and hold" circuit for all Bio-Chem Valve™ solenoid operated valves
- PTFE, Silicone and C-Flex® tubing

Trademarks

Trinamic® is a registered trademark of TRINAMIC Motion Control GmbH & Co. KG.

C-Flex® is a registered trademark of Saint-Gobain Performance Plastics

CoolCube™ is a trademark of Bio-Chem Fluidics Inc.

Bio-Chem Valve™ is a trademark of Bio-Chem Fluidics Inc.

BIO•CHEM
FLUIDICS

www.biochemfluidics.com

Bio-Chem Fluidics Inc
85 Fulton Street, Boonton NJ 07005 USA
t: (973) 263 3001 f: 973 263 2880 e: sales.us@biochemfluidics.com

Bio-Chem Fluidics Technology (Shanghai) Co. Ltd
South Metropolis Industrial Park, Jindu Road, Minhang District, Shanghai, PRC 201108
t: +86 21 61519058 f: +86 21 61519090

© Bio-Chem Fluidics 2012 / created by dsm-llc.com