



BIO-CHEM FLUIDICS

BIO-CHEM VALVE Solenoid Operated Flow Selection Valves



INDEX

Page 2	Flow Selection Valve General Information	
Page 3	Flow Selection Valve Selection Guide	
Page 4	Why Choose a Bio-Chem Valve™ Flow Selection Valve and Common Applications	
Page 5	040T Series Flow Selection Valves	
	Valves with 0.032" [0.81mm] and 0.054" [1.4mm] orifices and 1.9 Watt solenoids	
Page 6	080T Series Flow Selection Valves	
	Valves with 0.032" [0.81mm] and 0.062" [1.6mm] orifices and 2.6 Watt solenoids	
Page 9	105T Series Flow Selection Valves	
	Valves with 0.125" [3.2mm] orifices and 8.0 Watt solenoids	

FLOW SELECTION VALVES GENERAL INFORMATION

What is a Flow Selection Valve?

Bio-Chem Valve™ Flow Selection Valves combine multiple valve actuators into a single, compact unit. Because each actuator operates independently, Flow Selection Valves can combine or select any combination of between 2 and 8 individual source streams. Valves are situated around a central block, providing flow paths of equal length.

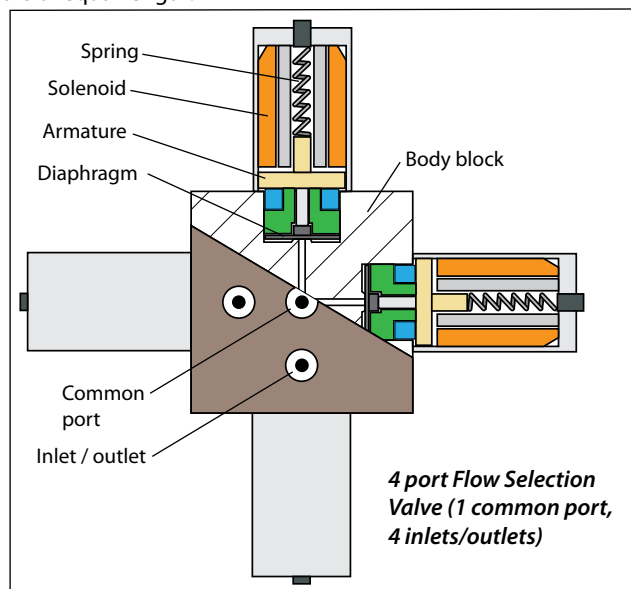

Flow Selection Valves are similar in construction to Bio-Chem Valve™ solenoid operated Isolation Valves. A flexible diaphragm isolates the solenoid actuation mechanism from the fluid path. When a valve is energized, the solenoid retracts the armature that is attached to the flexible diaphragm. This raises the diaphragm allowing fluid to flow between the common port and an outlet. When de-energized a spring forces the diaphragm down, closing off the flow path. Because the fluid path can be made from extremely inert materials (such as PTFE and PEEK), Bio-Chem Valve™ Flow Selection Valves are particularly suitable for use in highly aggressive and / or high purity fluid applications.

Features of a Bio-Chem Valve™ Flow Selection Valve.

- **Range of orifice sizes and power ratings.** The Bio-Chem Valve™ Flow Selection Valve range covers orifice sizes from 0.032" (0.8mm) to 0.125" (3.2mm) with solenoids rated from less than 2 Watts to 8 Watts in continuous operation. This range means that standard valves can handle many mixing and flow selection applications.
- **Precise flow characteristics.** Each solenoid actuator on the Flow Selection Valve is individually adjusted at the factory to ensure equal flow rates at the same pressure.
- **Compact, robust construction.** Combining 2, 3, 4, 5, 6 or 8 valves into one manifold block saves significant space within an instrument. The integral construction eliminates the need for tubing sets between valves.
- **Minimal dead volume.** The manifold is specifically designed to reduce the internal volume of the valve leading to minimal dead volume when compared to single, stand-alone valves or compared to manifolds with removable valves. The elimination of tubing sets further reduces the total internal volume of the system.
- **Equal length flow paths.** The radial layout of the manifold block ensures that all flow paths are identical. There are no differences in flow path length and timing as would be found in linear manifolds.
- **Inert fluid path.** Bio-Chem Valve™ Flow Selection Valves employ the same method of construction as the range of Isolation Valves. All wetted parts are manufactured from inert, non-metallic materials.

Flow Selection Valve Selection Guide

1. Select the number of valves / inlet ports. All Flow Selection Valves have the specified number of inlet ports PLUS a common port. For example, a 3-port valve has a total of four ports (three inlet and one common).
2. Select the orifice size. Orifice sizes range from Ø0.032" (0.81mm) to Ø0.125" (3.2mm).
3. Confirm that the appropriate materials of construction are available in the specified valve series (for material combinations not shown please contact your regional sales office).
4. Turn to the pages indicated to see full details and ordering information for each valve.

No. of valves	Series:	040T (pg. 5)				080T (pg. 6)						105T (pg. 9)
	Orifice:	0.032"		0.054"		0.032"			0.062"			0.125"
	Body Mat'l	PPS	PEEK	PPS	PEEK	PTFE	PPS	PEEK	PTFE	PPS	PEEK	PTFE
2	Diaphragm Material					PTFE	PTFE	PTFE	PTFE	PTFE	PTFE	PTFE
						PTFE	EPDM	EPDM	PTFE	EPDM	EPDM	PTFE
						PTFE	FFKM	FFKM	PTFE	FFKM	FFKM	PTFE
3		PTFE	PTFE	PTFE	PTFE	PTFE	PTFE	PTFE	PTFE	PTFE	PTFE	PTFE
		EPDM	EPDM	EPDM	EPDM	PTFE	EPDM	EPDM	PTFE	EPDM	EPDM	PTFE
		FFKM	FFKM	FFKM	FFKM	PTFE	FFKM	FFKM	PTFE	FFKM	FFKM	PTFE
4		PTFE	PTFE	PTFE	PTFE	PTFE	PTFE	PTFE	PTFE	PTFE	PTFE	PTFE
		EPDM	EPDM	EPDM	EPDM	PTFE	EPDM	EPDM	PTFE	EPDM	EPDM	PTFE
		FFKM	FFKM	FFKM	FFKM	PTFE	FFKM	FFKM	PTFE	FFKM	FFKM	PTFE
5						PTFE	PTFE	PTFE	PTFE	PTFE	PTFE	
						PTFE	EPDM	EPDM	PTFE	EPDM	EPDM	
						PTFE	FFKM	FFKM	PTFE	FFKM	FFKM	
6					PTFE	PTFE	PTFE	PTFE	PTFE	PTFE	PTFE	
					PTFE	EPDM	EPDM	PTFE	EPDM	EPDM	PTFE	
					PTFE	FFKM	FFKM	PTFE	FFKM	FFKM	PTFE	
8					PTFE	PTFE	PTFE	PTFE	PTFE	PTFE		
					PTFE	EPDM	EPDM	PTFE	EPDM	EPDM		
					PTFE	FFKM	FFKM	PTFE	FFKM	FFKM		

.....

Polymers referenced in this brochure:

EPDM = ethylene - propylene - diene monomer
 FFKM = perfluoro elastomer
 PEEK = polyetheretherketone
 PPS = polyphenylene sulfide
 PTFE = polytetrafluoroethylene

.....

Why choose a Flow Selection Valve?

Eliminate tubing between valves

Bio-Chem Valve™ Flow Selection Valves eliminate the need for tubing sets to connect between individual valves thereby reducing the number of connections and potential leak points.

Equivalence of internal flow paths

Unlike linear manifolds or valves connected by tubing sets, Flow Selection Valve flow paths are all the same length which means they have equal pressure drop, equal response times and equal internal volumes.

Individual control of flow paths

Unlike other valves with multiple ports, each flow path has its own associated actuation mechanism and can be controlled individually. This means that there is no need to pass one port to connect to another as with rotary valves.

Economic considerations

Flow Selection Valves offer an economic alternative to either: a) multiple single valves and their associated, necessary tubing sets, or b) multi-port valves that require sophisticated control systems for operation.



080T6 Flow Selection Valve. Note: Ports are equidistant from center common port ensuring that all flow paths are identical.

Applications

Bio-Chem Valve™ Flow Selection Valves are typically used in one of two main applications: Flow Mixing (flow from multiple inlets to one common outlet), and Flow Selection (flow from common inlet split into multiple outlets).

Flow Mixing

When Bio-Chem Valve™ Flow Selection Valves are used as flow mixing devices the flow from the inlets can be mixed together into a single stream under a variety of conditions:

- Each inlet can be selected individually so the outlet is one singular outgoing stream.
- Any combination of inlets can be selected so the outlet is a mixture of the incoming streams. Outlet composition will depend on pressure and fluid viscosity in each stream.
- Each inlet can be constantly adjusted to form a flow gradient. (Please discuss this special application with your regional sales office)

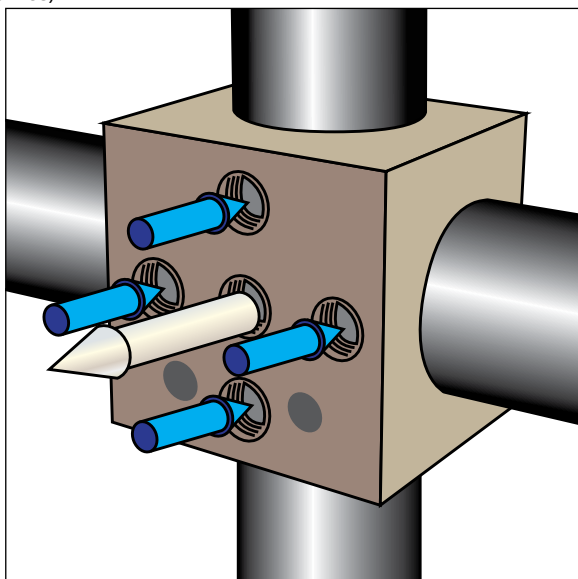

080T4 Flow Selection Valve used as flow mixing device

Flow Selection / Stream Splitting

When the flow pattern is reversed, Flow Selection Valves are used to divert flow from a common port to either a single or multiple outlets:

- In flow selection applications, the common inlet is diverted to one of the available outlets.
- For stream splitting, the common inlet is split between the available outlets either in a fixed or adjustable percentage. The split can be controlled from one outlet up to the maximum number of outlets in that valve.

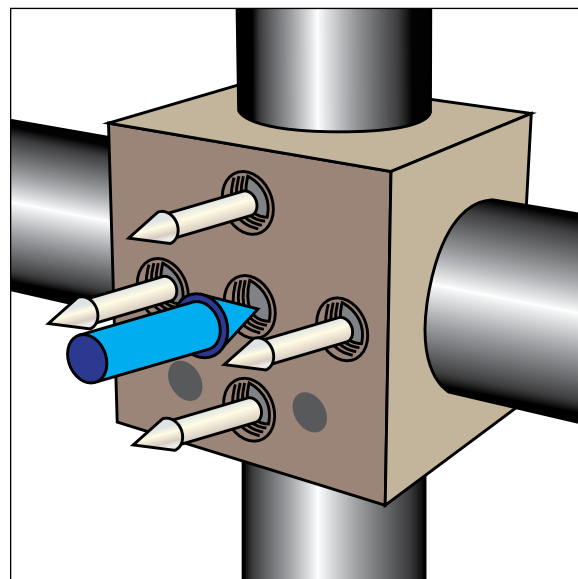

080T4 Flow Selection Valve in flow splitting application

040T SERIES FLOW SELECTION VALVES

- 040T Flow Selection Valve available with either 3 or 4 valves / inlet ports and two orifice sizes (0.032" / 0.81mm and 0.054" / 1.4mm)
- Design based on 0.38" (9.5mm) diameter high efficiency solenoid
- Valve life above 2 million cycles
- Chemically resistant PPS or PEEK body with choice of PTFE, EPDM or FFKM diaphragm
- Low power requirements (1.9 Watts, 0.17 amps @ 12VDC; 1.9 Watts, 0.08 amps @ 24VDC) and minimal heat generation
- Maximum operating pressure = 20 psi

040T424-54-4E Flow Selection Valve
(4 inlet ports, 0.054" orifice, PPS body, EPDM diaphragm)



Ordering info, 040T series

PART NO.	BODY MAT'L	DIA. MAT'L	INT. VOL (µL)	
			COM. PORT	INLET PORT(ea)
12V DC, 3-port, 0.032" orifice				
040T312-32-4	PPS	PTFE	28	21
040T312-32-4E	PPS	EPDM	28	21
040T312-32-4P	PPS	FFKM	28	21
040T312-32-5	PEEK	PTFE	28	21
040T312-32-5E	PEEK	EPDM	28	21
040T312-32-5P	PEEK	FFKM	28	21

PART NO.	BODY MAT'L	DIA. MAT'L	INT. VOL (µL)	
			COM. PORT	INLET PORT(ea)
12V DC, 4-port, 0.032" orifice				
040T412-32-4	PPS	PTFE	36	21
040T412-32-4E	PPS	EPDM	36	21
040T412-32-4P	PPS	FFKM	36	21
040T412-32-5	PEEK	PTFE	36	21
040T412-32-5E	PEEK	EPDM	36	21
040T412-32-5P	PEEK	FFKM	36	21

PART NO.	BODY MAT'L	DIA. MAT'L	INT. VOL (µL)	
			COM. PORT	INLET PORT(ea)
12V DC, 3-port, 0.054" orifice				
040T312-54-4	PPS	PTFE	60	44
040T312-54-4E	PPS	EPDM	60	44
040T312-54-4P	PPS	FFKM	60	44
040T312-54-5	PEEK	PTFE	60	44
040T312-54-5E	PEEK	EPDM	60	44
040T312-54-5P	PEEK	FFKM	60	44

PART NO.	BODY MAT'L	DIA. MAT'L	INT. VOL (µL)	
			COM. PORT	INLET PORT(ea)
12V DC, 4-port, 0.054" orifice				
040T412-54-4	PPS	PTFE	77	44
040T412-54-4E	PPS	EPDM	77	44
040T412-54-4P	PPS	FFKM	77	44
040T412-54-5	PEEK	PTFE	77	44
040T412-54-5E	PEEK	EPDM	77	44
040T412-54-5P	PEEK	FFKM	77	44

* for 24V replace 040Tx12 with 040Tx24 where x=number of ports

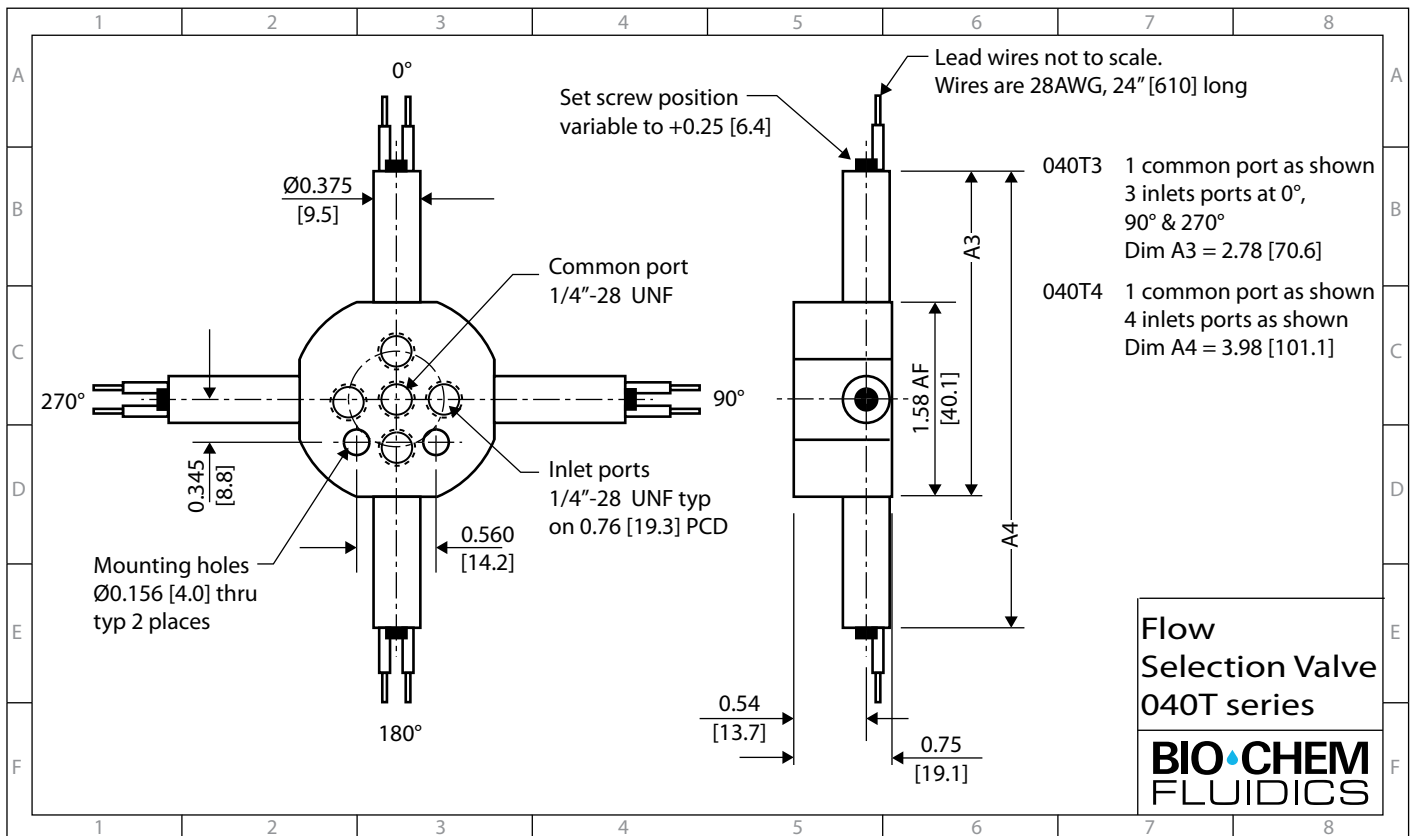

080T SERIES FLOW SELECTION VALVES

- 080T Flow Selection Valve available with either 2, 3, 4, 5, 6 or 8 valves / inlet ports and two orifice sizes (0.032" / 0.81mm and 0.062" / 1.6mm)
- Design based on 0.75" (19.1mm) diameter high efficiency solenoid
- Valve life above 2 million cycles
- Chemically resistant PTFE, PPS or PEEK body with choice of PTFE, EPDM or FFKM diaphragm
- Low power requirement (2.6 Watts, 0.22 amps @ 12VDC; 2.6 Watts, 0.10 amps @ 24VDC) and minimal heat generation
- Maximum operating pressure = 20 psi

Ordering info, 080T series

PART NO. BODY MAT'L DIA. MAT'L INT. VOL (μL)
COM. PORT INLET PORT(ea)

12V DC, 2-port, 0.032" orifice

080T212-32	PTFE	PTFE	7	14
080T212-32-4	PPS	PTFE	7	14
080T212-32-4E	PPS	EPDM	7	14
080T212-32-4P	PPS	FFKM	7	14
080T212-32-5	PEEK	PTFE	7	14
080T212-32-5E	PEEK	EPDM	7	14
080T212-32-5P	PEEK	FFKM	7	14

12V DC, 2-port, 0.062" orifice

080T212-62	PTFE	PTFE	27	15
080T212-62-4	PPS	PTFE	27	15
080T212-62-4E	PPS	EPDM	27	15
080T212-62-4P	PPS	FFKM	27	15
080T212-62-5	PEEK	PTFE	27	15
080T212-62-5E	PEEK	EPDM	27	15
080T212-62-5P	PEEK	FFKM	27	15

12V DC, 3-port, 0.032" orifice

080T312-32	PTFE	PTFE	24	15
080T312-32-4	PPS	PTFE	24	15
080T312-32-4E	PPS	EPDM	24	15
080T312-32-4P	PPS	FFKM	24	15
080T312-32-5	PEEK	PTFE	24	15
080T312-32-5E	PEEK	EPDM	24	15
080T312-32-5P	PEEK	FFKM	24	15

12V DC, 3-port, 0.062" orifice

080T312-62	PTFE	PTFE	91	35
080T312-62-4	PPS	PTFE	91	35
080T312-62-4E	PPS	EPDM	91	35
080T312-62-4P	PPS	FFKM	91	35
080T312-62-5	PEEK	PTFE	91	35
080T312-62-5E	PEEK	EPDM	91	35
080T312-62-5P	PEEK	FFKM	91	35

From left to right, 080T6 Flow Selection Valve (PTFE body), 080T2 Flow Selection Valve (PTFE body), 080T4 Flow Selection Valve (PEEK body)



PART NO. BODY MAT'L DIA. MAT'L INT. VOL (μL)
COM. PORT INLET PORT(ea)

12V DC, 4-port, 0.032" orifice

080T412-32	PTFE	PTFE	30	15
080T412-32-4	PPS	PTFE	30	15
080T412-32-4E	PPS	EPDM	30	15
080T412-32-4P	PPS	FFKM	30	15
080T412-32-5	PEEK	PTFE	30	15
080T412-32-5E	PEEK	EPDM	30	15
080T412-32-5P	PEEK	FFKM	30	15

12V DC, 4-port, 0.062" orifice

080T412-62	PTFE	PTFE	117	35
080T412-62-4	PPS	PTFE	117	35
080T412-62-4E	PPS	EPDM	117	35
080T412-62-4P	PPS	FFKM	117	35
080T412-62-5	PEEK	PTFE	117	35
080T412-62-5E	PEEK	EPDM	117	35
080T412-62-5P	PEEK	FFKM	117	35

12V DC, 5-port, 0.032" orifice

080T512-32	PTFE	PTFE	45	15
080T512-32-4	PPS	PTFE	45	15
080T512-32-4E	PPS	EPDM	45	15
080T512-32-4P	PPS	FFKM	45	15
080T512-32-5	PEEK	PTFE	45	15
080T512-32-5E	PEEK	EPDM	45	15
080T512-32-5P	PEEK	FFKM	45	15

12V DC, 5-port, 0.062" orifice

080T512-62	PTFE	PTFE	174	15
080T512-62-4	PPS	PTFE	174	15
080T512-62-4E	PPS	EPDM	174	15
080T512-62-4P	PPS	FFKM	174	15
080T512-62-5	PEEK	PTFE	174	15
080T512-62-5E	PEEK	EPDM	174	15
080T512-62-5P	PEEK	FFKM	174	15

Ordering info, 080T series (continued)

PART NO.	BODY MAT'L	DIA. MAT'L	INT. VOL. (μ L)	
			COM. PORT	INLET PORT(ea)
12V DC, 6-port, 0.032" orifice				
080T612-32	PTFE	PTFE	53	15
080T612-32-4	PPS	PTFE	53	15
080T612-32-4E	PPS	EPDM	53	15
080T612-32-4P	PPS	FFKM	53	15
080T612-32-5	PEEK	PTFE	53	15
080T612-32-5E	PEEK	EPDM	53	15
080T612-32-5P	PEEK	FFKM	53	15
12V DC, 6-port, 0.062" orifice				
080T612-62	PTFE	PTFE	207	35
080T612-62-4	PPS	PTFE	207	35
080T612-62-4E	PPS	EPDM	207	35
080T612-62-4P	PPS	FFKM	207	35
080T612-62-5	PEEK	PTFE	207	35
080T612-62-5E	PEEK	EPDM	207	35
080T612-62-5P	PEEK	FFKM	207	35

PART NO.	BODY MAT'L	DIA. MAT'L	INT. VOL. (μ L)	
			COM. PORT	INLET PORT(ea)
12V DC, 8-port, 0.032" orifice				
080T812-32	PTFE	PTFE	96	15
080T812-32-4	PPS	PTFE	96	15
080T812-32-4E	PPS	EPDM	96	15
080T812-32-4P	PPS	FFKM	96	15
080T812-32-5	PEEK	PTFE	96	15
080T812-32-5E	PEEK	EPDM	96	15
080T812-32-5P	PEEK	FFKM	96	15
12V DC, 8-port, 0.062" orifice				
080T812-62	PTFE	PTFE	373	35
080T812-62-4	PPS	PTFE	373	35
080T812-62-4E	PPS	EPDM	373	35
080T812-62-4P	PPS	FFKM	373	35
080T812-62-5	PEEK	PTFE	373	35
080T812-62-5E	PEEK	EPDM	373	35
080T812-62-5P	PEEK	FFKM	373	35

* for 24V replace 080Tx12 with 080Tx24 where x=number of ports

INSTALLATION DRAWING 080T2 SERIES

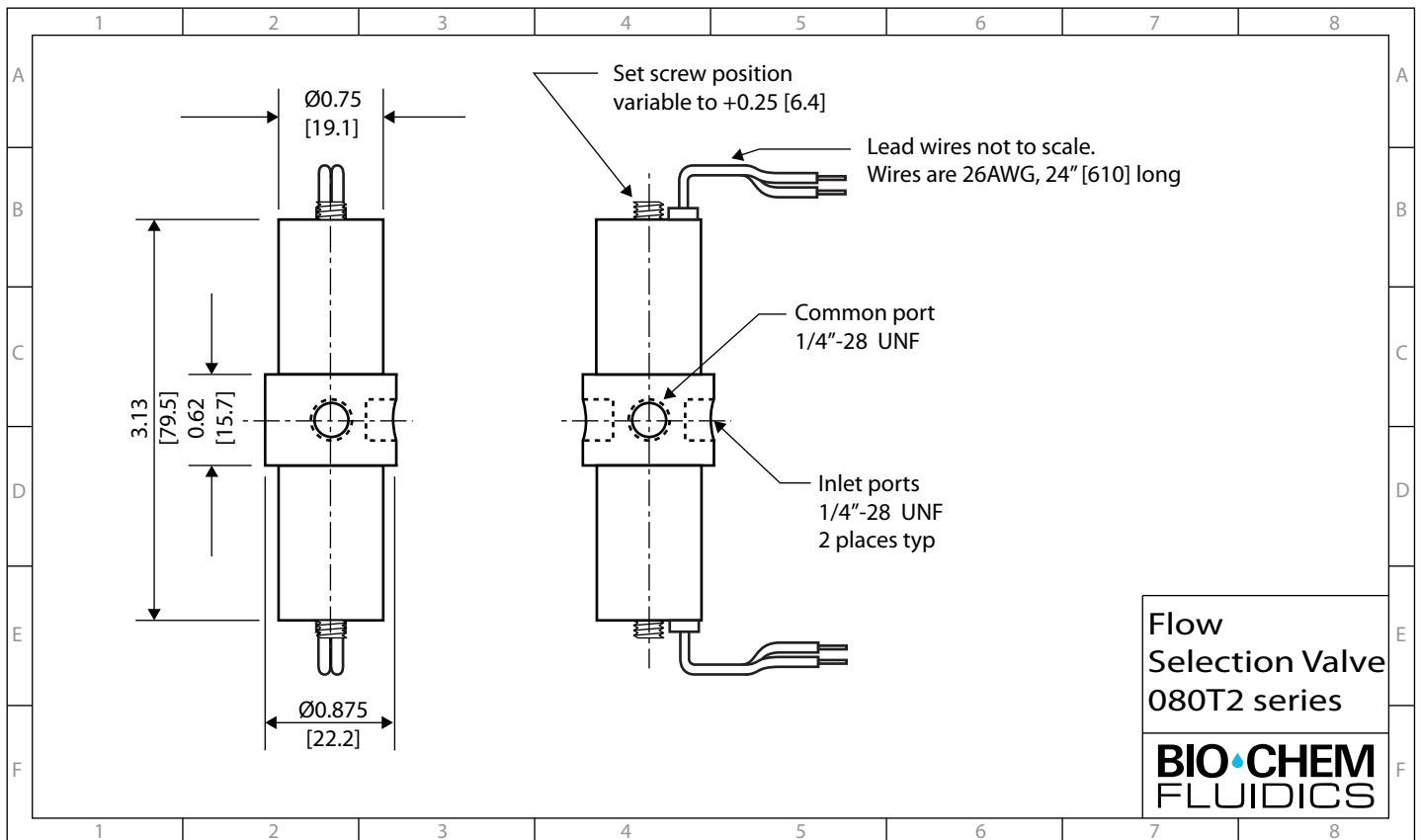

080T SERIES FLOW SELECTION VALVES continued

INSTALLATION DRAWING 080T3 - 080T8

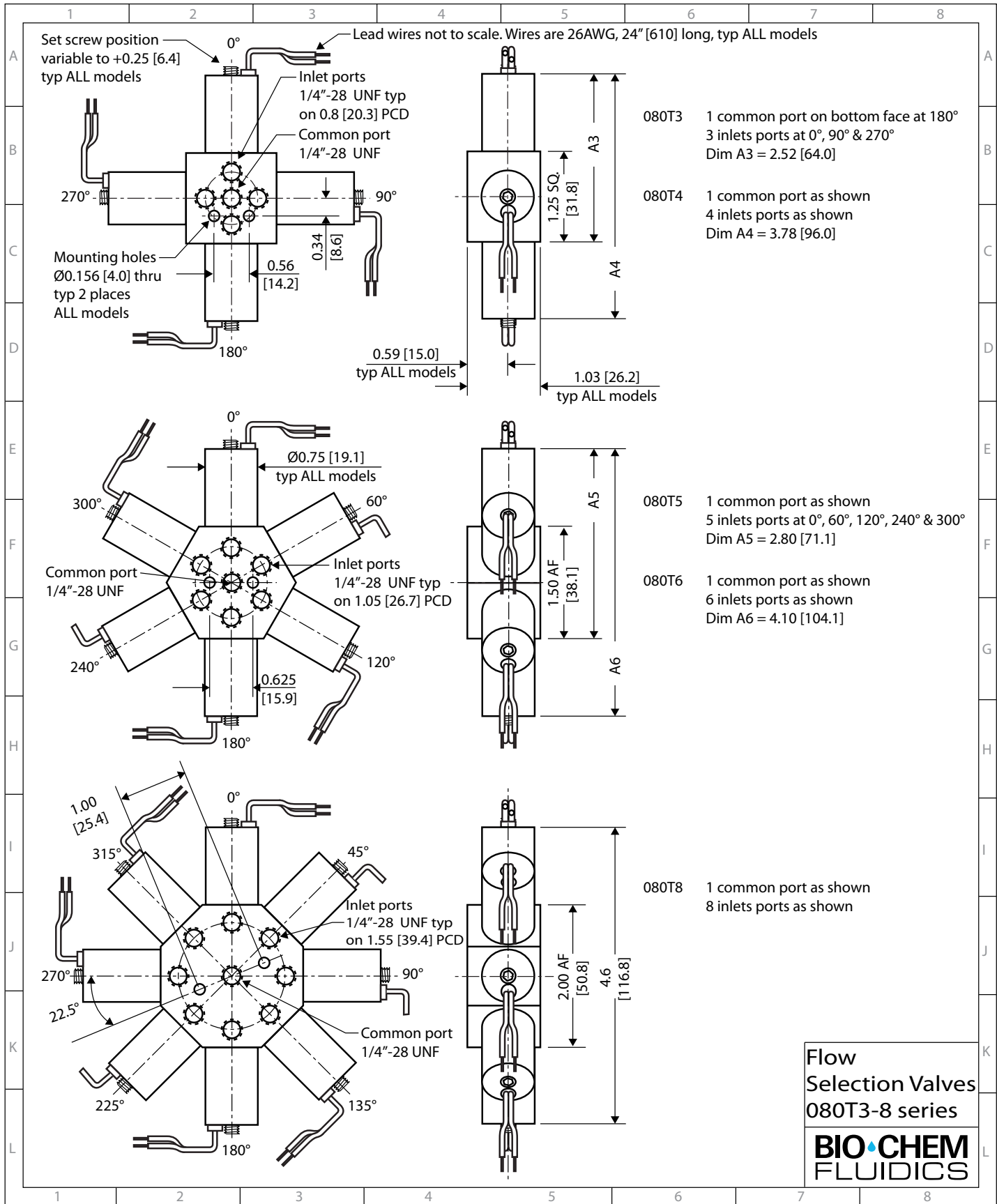

105T SERIES FLOW SELECTION VALVES

- 105T Flow Selection Valve available with either 2, 3, 4 or 6 valves / inlet ports and a 0.125" / 3.2mm orifice
- Design based on 1.0" (25.4mm) diameter high efficiency solenoid
- Valve life above 2 million cycles
- Chemically resistant PTFE body with PTFE diaphragm
- Low power requirement (8.0 Watts, 0.063 amps at 12VDC; 8.0 Watts, 0.033 amps at 24VDC) and minimal heat generation
- Maximum operating pressure = 10 psi



105T3 Flow Selection Valve
(3 inlet ports, 0.125" orifice, PTFE body, PTFE diaphragm)

Ordering info, 105T series

PART NO.	BODY MAT'L	DIA. MAT'L	INT. VOL (µL)	
			COM. PORT	INLET PORT(ea)
12V DC, 2-port, 0.125" orifice				
105T212-125	PTFE	PTFE	146	233
12V DC, 3-port, 0.125" orifice				
105T312-125	PTFE	PTFE	444	240

PART NO.	BODY MAT'L	DIA. MAT'L	INT. VOL (µL)	
			COM. PORT	INLET PORT(ea)
12V DC, 4-port, 0.125" orifice				
105T412-125	PTFE	PTFE	573	240
12V DC, 6-port, 0.125" orifice				
105T612-125	PTFE	PTFE	1175	240

* for 24V replace 105Tx12 with 105Tx24 where x=number of ports

INSTALLATION DRAWING 105T2 SERIES

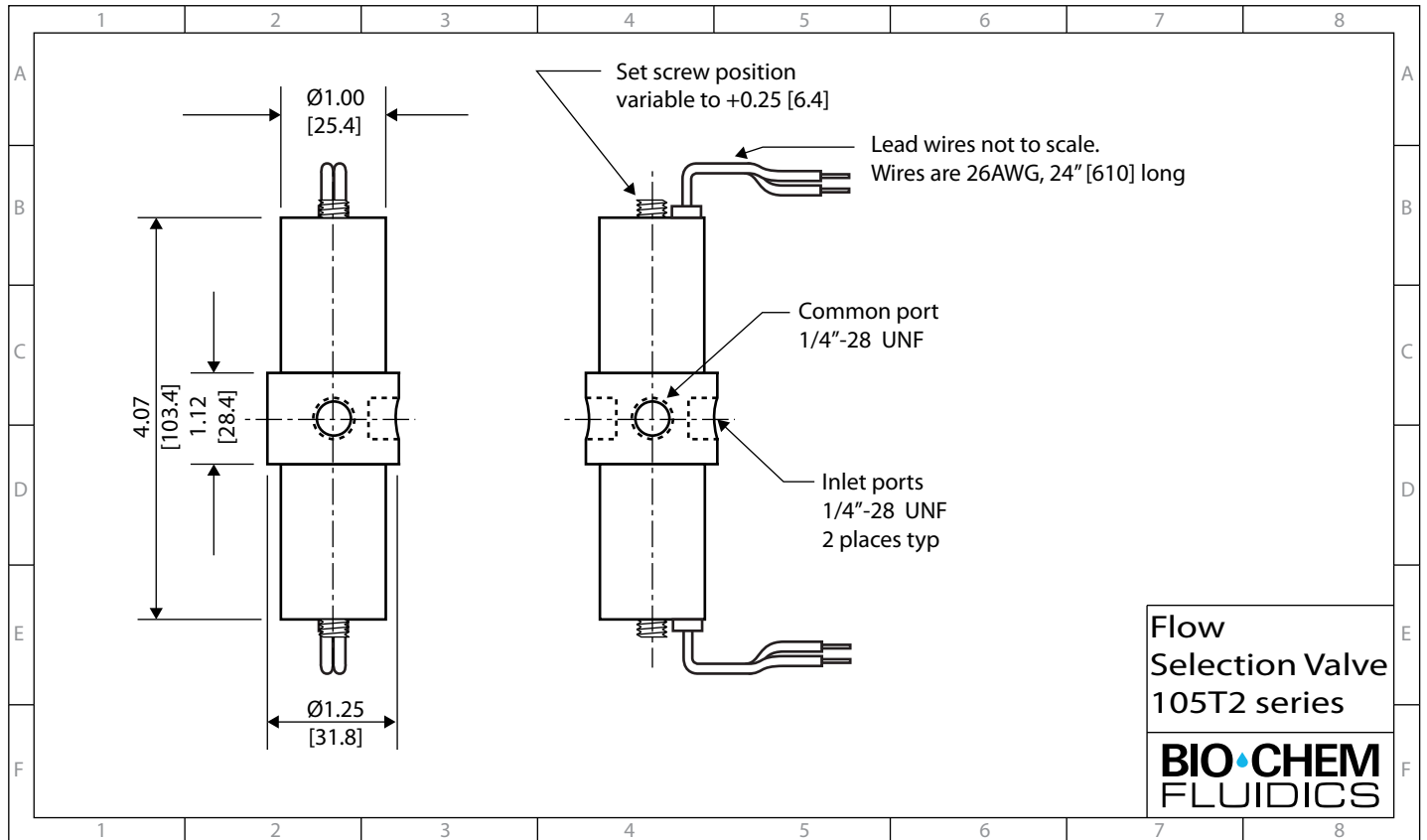

Flow Selection Valve
105T2 series
BIO-CHEM
FLUIDICS

105T SERIES FLOW SELECTION VALVES continued

INSTALLATION DRAWING 105T3 - 105T6

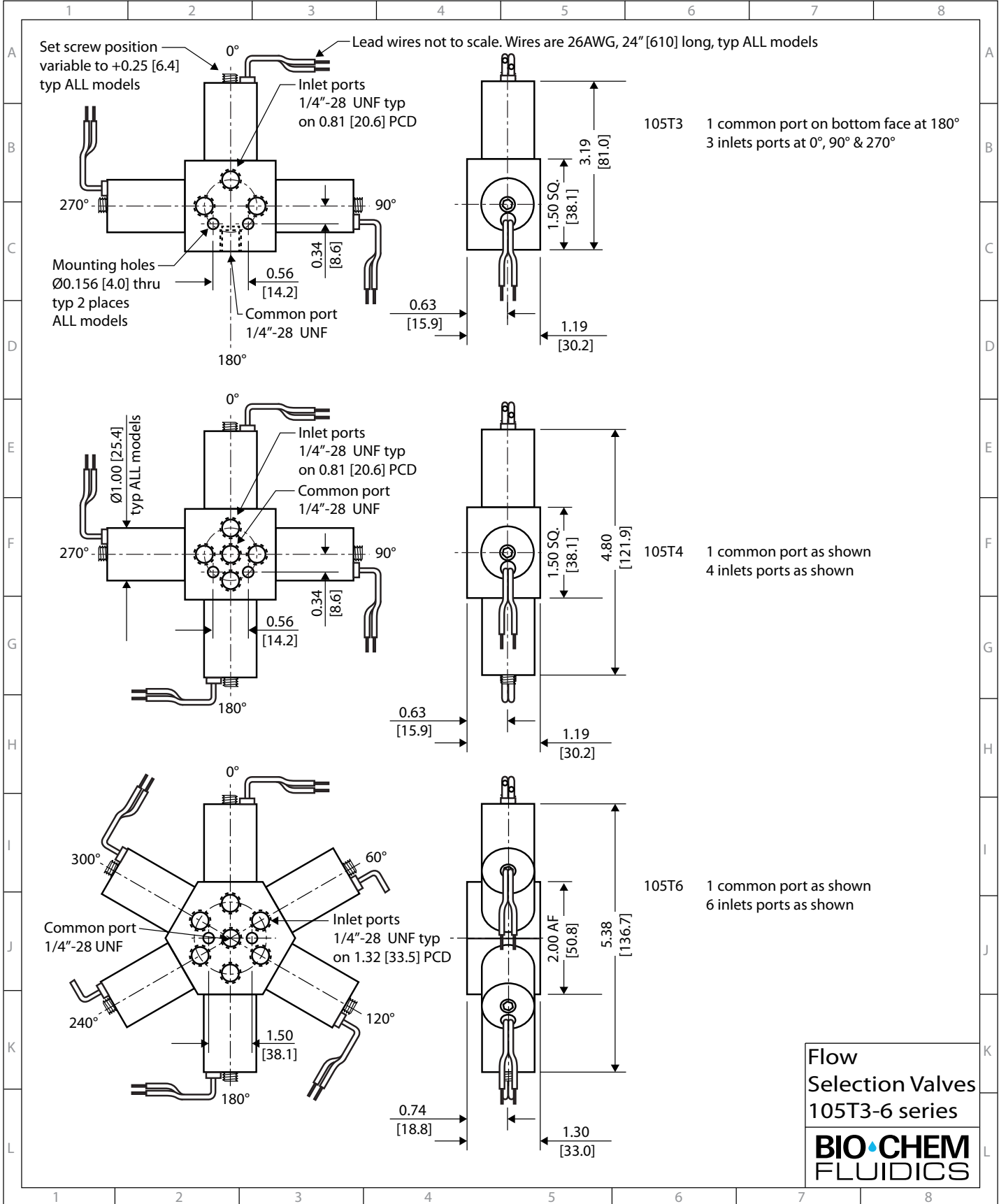

THE BIO-CHEM FLUIDICS BRAND FAMILY

Bio-Chem Fluidics is dedicated to providing instrument manufacturers and laboratories with the industry's best choice of inert, miniature fluid handling components.

Under the Bio-Chem Valve™ brand name we offer a complete fluid system solution for a wide range of industries including analytical chemistry, clinical diagnostics and medical device manufacturers as well as the scientific community.

BIO-CHEM VALVE

INERT SOLENOID VALVES AND PUMPS, ELECTRIC ROTARY VALVES

MICRO-PUMPS



ISOLATION VALVES



FLOW SELECTION VALVES

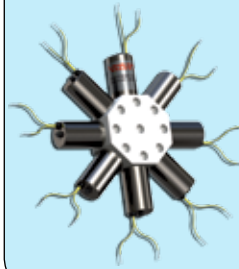

PINCH VALVES



ELECTRIC ROTARY VALVES



MANIFOLD ASSEMBLIES



ACCESSORIES



CUSTOMIZATION SERVICES



Trademarks
Bio-Chem Valve™ is a trademark of Bio-Chem Fluidics Inc.

BIO·CHEM
FLUIDICS

www.biochemfluidics.com

Bio-Chem Fluidics Inc
85 Fulton Street, Boonton NJ 07005 USA
t: (973) 263 3001 f: 973 263 2880 e: sales.us@biochemfluidics.com

Bio-Chem Fluidics Technology (Shanghai) Co. Ltd
South Metropolis Industrial Park, Jindu Road, Minhang District, Shanghai, PRC 201108
t: +86 21 61519058 f: +86 21 61519090